

IRONING BOARD INSTALLATION INSTRUCTIONS

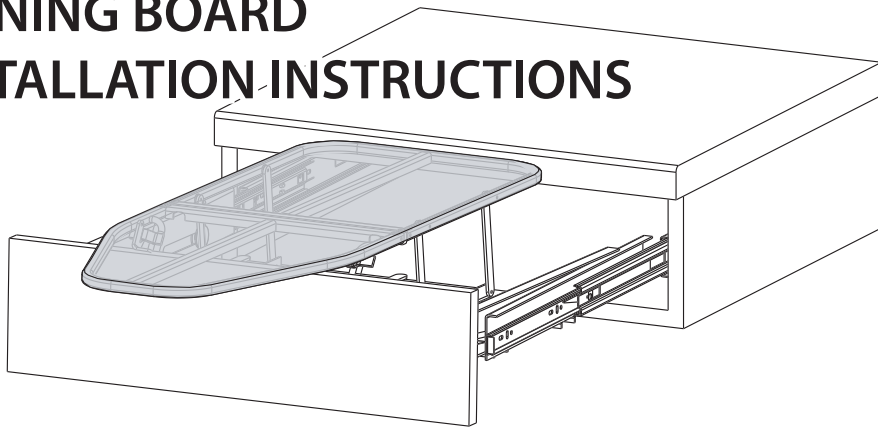

Tools Needed for Installation:
10mm Open/Boxed end wrench

Phillips Screwdriver

Tape Measure

Marking Pen

5mm Allen Wrench (Included)

Double Sided Tape (Included)

(18) #8x1/2" Flat Head Mounting Screws (Included)

The Ironing Board is designed to mount in closet and vanity cabinets with widths between 14½" and 21", as well as depths of at least 16" for the IB-16-CR, and 20" for the IB-18-CR.

Step 1. Remove Ball Bearing slides from unit, by extending them fully, depressing the black release lever, and pulling apart from the remainder of the slide assembly.



Step 2. For face frame cabinet installation create a pair of side spacers by cutting a piece of wood at least 2½" tall, and as thick as the distance the face frame protrudes from the inside edge of the cabinet. Install it into the inside of the cabinet parallel with front opening. This is not necessary with frameless cabinet designs.

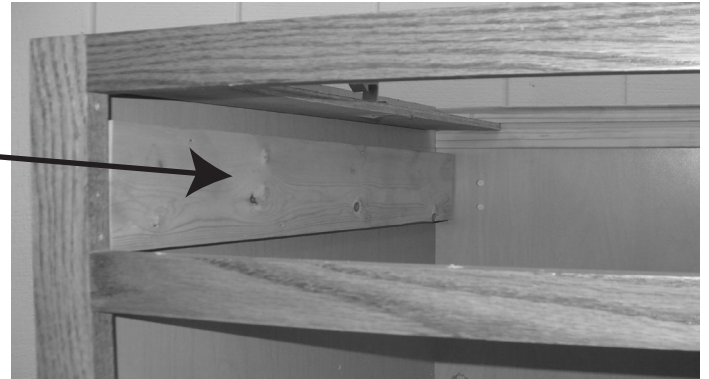

Step 3. Mark the location of the front mounting hole by measuring UP 1¾" from the LOWEST point of your opening and BACK ¼" from the front of the opening. Once marked install slides to side of cabinet insuring they are level.



Step 4. Using the 5mm Allen wrench, and 10mm wrench, remove the board and front support from the friction slide units.

Step 5. Once the ironing board, and front support is removed. Re-assemble the slides as shown.

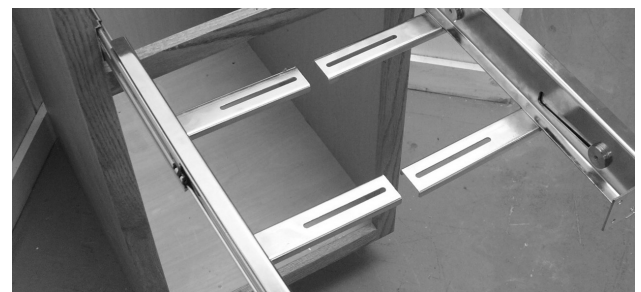

Step 6. With both slides full closed and inside the cabinet, apply the double-sided tape to the front of the slide flanges. use a small spacer in the friction slide assembly as shown if needed to insure that cross braces are horizontal, and parallel.

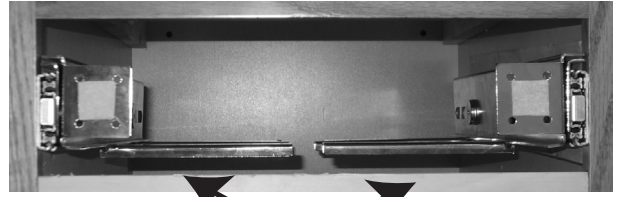

Cross braces **MUST** be parallel and horizontal

Step 7. CAREFULLY line up your drawer front, and “stick” it to the front of the slides with the supplied double-sided tape. You can now carefully pull on the drawer head to open the drawer. Once slightly open it is recommended to pull on the slides not the drawer. Attach the drawer head to the slides with (8) of the provided #8 flathead screws.



Step 8. With drawer front attached re-install the board, support brackets, and mechanism into the drawer being sure to have the front wire support held in place on the drawer front by the support brackets. Also insure that the bolt heads are on the **BOTTOM** of the unit. This is critical due to the tight fit of this product.

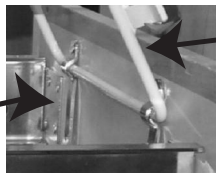

Front wire support

Support Bracket

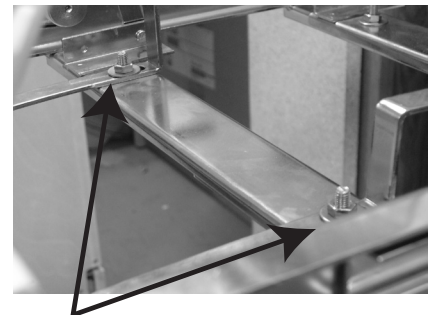

Re-install nuts on top for clearance

Step 9. Use (4) #8 flathead screws to attach the support brackets to the drawer front.



Step 10. Fold then slide board into drawer, and check for proper operation, and make any adjustments necessary.

Operation Instructions

Lift and release latch on bottom side of board before folding board back into closed position. Make sure board is fully closed, and lift drawer head before pushing board back into cabinet.

Questions? Call our Customer Service Specialist at 800-626-1126 or visit us online at www.rev-a-shelf.com



2409 Plantside Drive
Jeffersontown, KY 40299