

# SURFACE-MOUNT CONCEALED HINGE



# HES2S-150-A110

HINGES

CONCEALED HINGE



- Surface mounts to the door frame for easy installation.
- Minimum door thickness is 1-3/8" (35 mm) or more.
- Center mounting the hinge on a 1-3/8" (35 mm) door allows the door to be installed as a right-handed or left-handed door.
- 3D Adjustment: Adjust vertically, horizontally, and depth.
- Max opening angle is 110°. Please use door stopper to prevent overextension of hinge.

### Application



No mortising on the jamb side is required.

### 90° Opening (Without Cover)

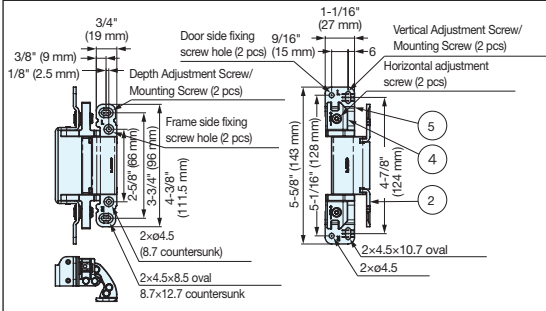

### 110° Opening (With Cover)

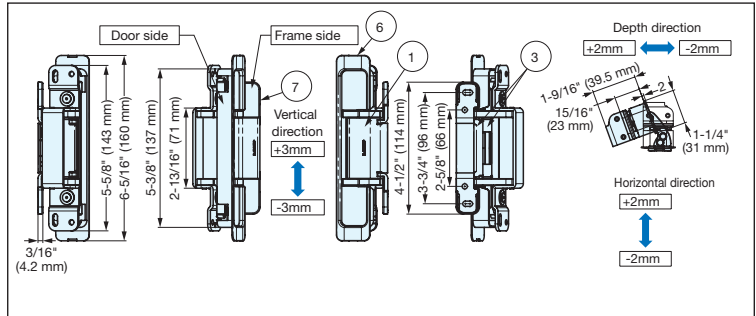

### Locus Chart

Drill at the door corner (B). The frame corner (A) can be used even without machining.

Y: Door Machining Margin	B: Door chamfering	A: Frame chamfering
4.5 or below	1 or higher	-

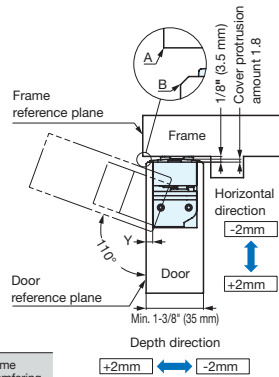

### Cut Out Dimensions

Drill pilot holes at the positions of the adjustment and locating screws.

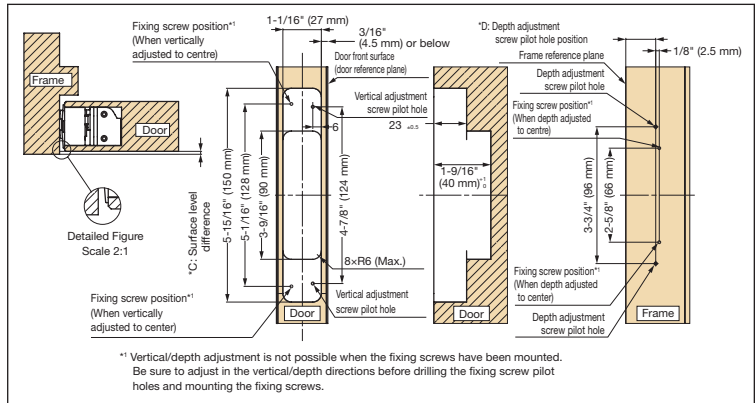

\*\* Vertical/depth adjustment is not possible when the fixing screws have been mounted. Be sure to adjust in the vertical/depth directions before drilling the fixing screw pilot holes and mounting the fixing screws.

1-3/8" (35 mm) door (machining margin 4 mm)	
*C: Surface level difference	*D: Adjustment screw pilot hole position
0	3/4" (19 mm)
1	13/16" (20 mm)
2	13/16" (21 mm)
3	7/8" (22 mm)
4	15/16" (23 mm)
5	15/16" (24 mm)

No.	Part Name	Material	Finish
①	Body	POM	-
②	Base Plate	SPCC	Chrome
③	Arm	Zinc Alloy	Chemical Treatment
④	Inner Socket		Chrome
⑤	Outer Socket	SPCC	-
⑥	Socket Cover	ABS	-
⑦	Base Plate Cover		-

Item No.	Color	Door Width	Door Height	Door Thickness	Door Weight/ 2 pcs	Door Weight/ 3 pcs	Opening Angle	Weight (g)	Box (pcs)	Carton (pcs)
HES2S-150-A110-WT	White	Max. 35-7/16" (900 mm)	Max. 106-5/16" (2700 mm)	Min. 1-3/8" (35 mm)	Max. 88 lbs (40 kg)	Max. 110 lbs (50 kg)	110°	272	2	24
HES2S-150-A110-BL	Black									
HES2S-150-A110-WGR	Warm Grey									