



ELITE PLUS



**G\*GRASS®**

## ELITE PLUS SLIDE SYSTEM

Undermount drawer technology with advanced running performance and smooth soft-closing action





Bringing together fast installation, easy adjustment, and smooth running performance at a great value.



#### Designed for uncompromised performance

The exceptional design of Elite Plus drawer slide draws attention to the beauty of your cabinetry and leaves the mounted hardware completely out of sight. The Elite Plus brings together the advances of undermount technology with a precision roller carriage and features a liquid damper that is designed for a smoother closing transition.

Offered in a full range of lengths for frameless and face frame construction, the Elite Plus features full drawer extension for maximum use of interior space. It is a proven undermount slide with an ample load capacity of 100 lb that meets and exceeds ANSI/BHMA Grade 1 testing standards. The front locking devices offer 1D height adjustment or 2D height and side adjustment. Multiple cleats securely connect the drawer to the slide. Year after year, Elite Plus enables drawers to function quietly and flawlessly with the quality construction and Grass standard of excellence you have come to expect.

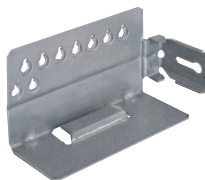

## Table of Content

	Description	Adjustment	Page
	<b>Features &amp; Benefits</b>		4
	<b>Technical Information</b>		6
	<b>Elite Plus 16</b> <ul style="list-style-type: none"> <li>• Integrated Soft-close</li> <li>• Full extension</li> <li>• For 16mm (5/8") material</li> </ul>	<b>Front locking device selection provides:</b> <ul style="list-style-type: none"> <li>• Height adjustment (max +2.5mm)</li> <li>• Side adjustment (max ± 1.5mm)</li> </ul>	10
	<b>Elite Plus 19</b> <ul style="list-style-type: none"> <li>• Integrated Soft-close</li> <li>• Full extension</li> <li>• For 19mm (3/4") material</li> </ul>	<b>Front locking device selection provides:</b> <ul style="list-style-type: none"> <li>• Height adjustment (max +2.5mm)</li> <li>• Side adjustment (max ± 1.5mm)</li> </ul>	12
	<b>Accessories and Assembly Aids</b> <ul style="list-style-type: none"> <li>• V-notch Brackets</li> <li>• Drilling Template</li> <li>• Screws</li> <li>• Bumper Pads</li> </ul>		14

# Features and Benefits

## Elite Plus

### Features



- Slide is concealed to give full view of finely crafted drawers
- Self-latching front locking devices have easy release levers for drawer removal
- Liquid damper softly glides drawers to a stop
- For drawer material thickness: 12.7mm (1/2") to 19mm (3/4")
- Precision smooth running synthetic roller carriages
- Zinc plated roll formed steel composition
- Full extension for complete drawer access
- Height adjustment +2.5mm (3/32") with suitable front locking device
- Side adjustment  $\pm 1.5\text{mm}$  (1/16") with suitable front locking device
- Weight capacity: 100 lb dynamic, 100 lb static
- Wide drawer member provides stability between the cabinet and drawer member
- Meet and exceeds ANSI/BHMA A156.9 Standard, Grade 1

#### Multiple cleats

For secure front locking.

#### Depth Adjustment

4mm (5/32") allows perfect alignment for the drawer front.



#### 1D Front locking device

with height adjustment  
+2.5mm (3/32")

The front locking device securely connects the drawer to the slide.



#### 2D Front locking device

with height adjustment  
+2.5mm (3/32")  
with side adjustment  
 $\pm 1.5\text{mm}$  (1/16")

The front locking device securely connects the drawer to the slide.

## Features

- Soft-closing mechanism fully enclosed
- Precision German made liquid damper
- Face frame and frameless applications
- Uses same front locking devices as Maxcess
- Rear notch in back of box is 35mm for Maxcess and Elite Plus
- Patented technology

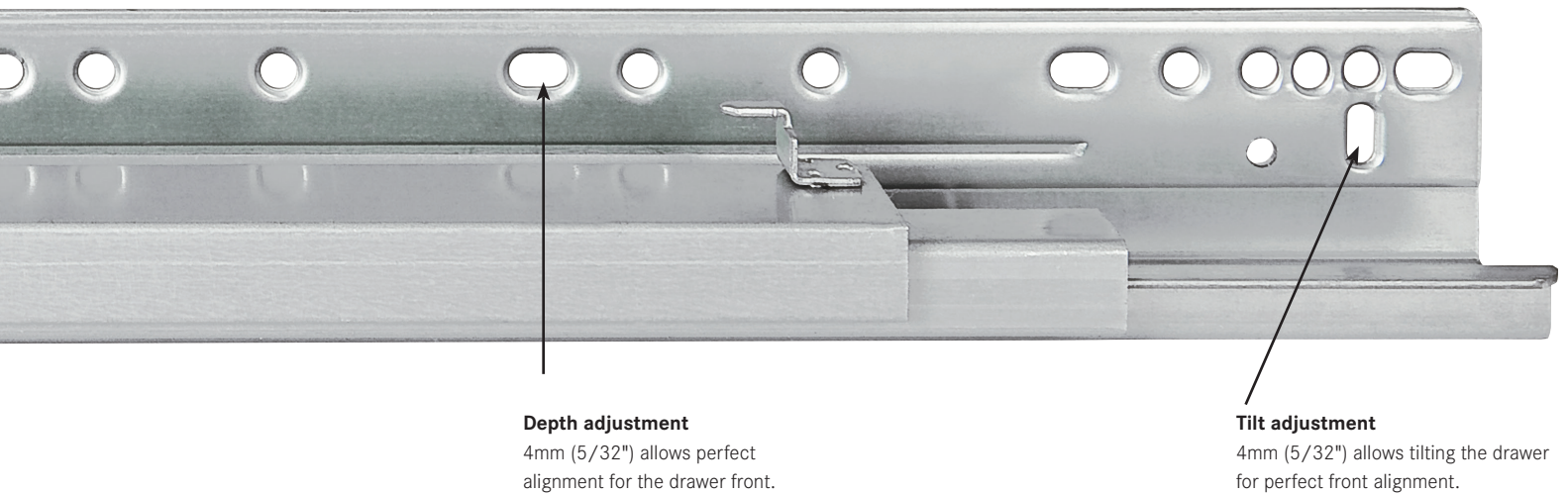
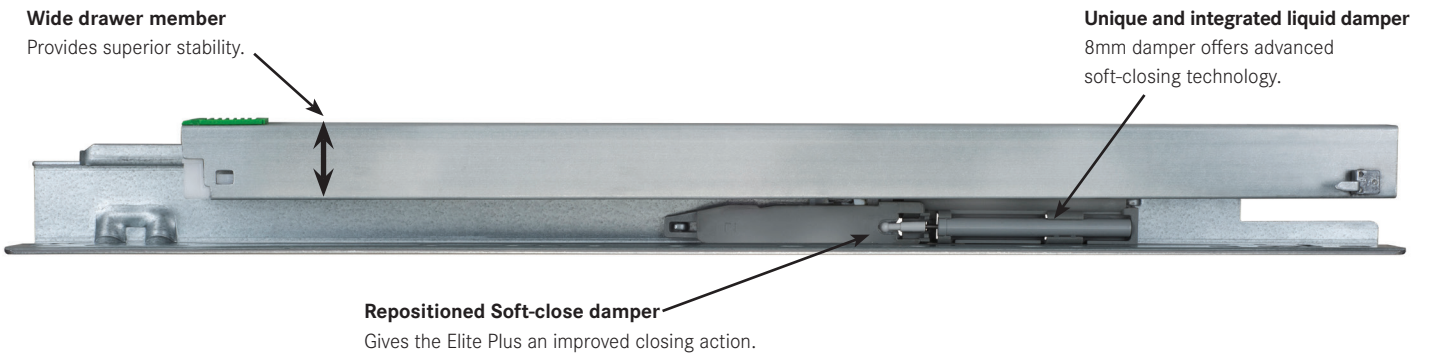

**Self-aligning rear mount bracket**  
Brackets self-align the drawer when cabinets are out of square,  $\pm 2\text{mm}$  (3/32") adjustment range.

For additional rear mount brackets see page 14.

# Technical Information

## Elite Plus

### Front Locking Device with Height Adjustment

#### 7523 Front Locking Device, 1D



- Securely connects the drawer to the slide
- Height adjustment range: +2.5mm (3/32")
- For standard width drawers
- Minimum inside drawer width 125mm (4 15/16")
- Lightweight, high strength material

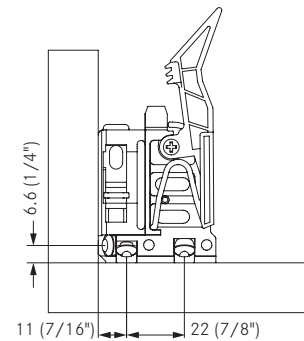

#### 7523 Flanged Front Locking Device, 1D



- Securely connects the drawer to the slide
- Height adjustment range: +2.5mm (3/32")
- For standard width drawers
- Minimum inside drawer width 125mm (4 15/16")
- Lightweight, high strength material

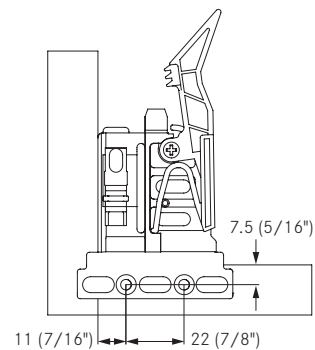

### Front Locking Device with Height Adjustment and Side Adjustment

#### 75X3 Front Locking Device, 2D

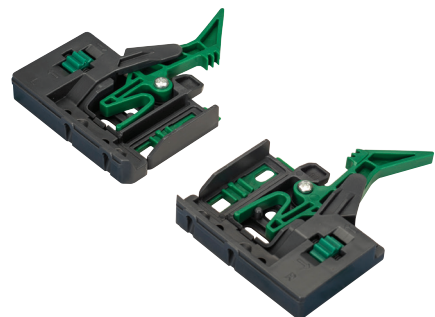

- Securely connects the drawer to the slide
- Height adjustment range: +2.5mm (3/32")
- Side adjustment range:  $\pm 1.5$ mm (1/16")
- For standard width drawers
- Minimum inside drawer width 140mm (5 1/4")
- Lightweight, high strength material

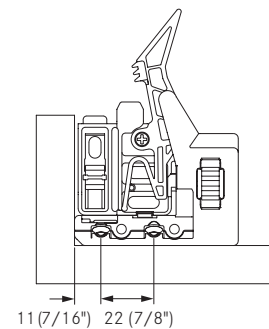

#### 75X3 Flanged Front Locking Device, 2D



- Securely connects the drawer to the slide
- Height adjustment range: +2.5mm (3/32")
- Side adjustment range:  $\pm 1.5$ mm (1/16")
- For standard width drawers
- Minimum inside drawer width 140mm (5 1/4")
- Lightweight, high strength material

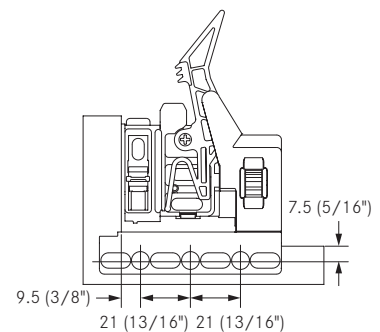

## Rear Mounting Brackets

### Universal Rear Mounting Bracket



- For all Elite Plus drawers
- For face frame application

Pre-drilling recommended  $\text{Ø}2.5\text{mm}$  ( $3/32''$ )

Use a minimum of 3 screws per bracket,  
#6 x  $1/2''$  truss head screws.

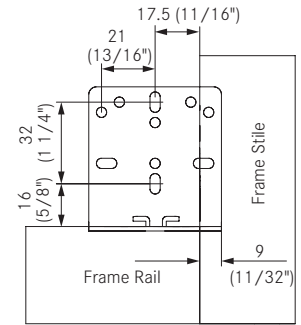

### V-notch Rear Mounting Brackets, 19mm

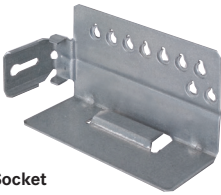

No Socket

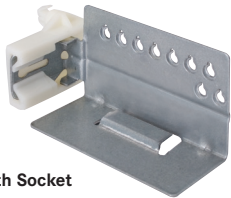

With Socket

- For all Elite Plus drawers
- For face frame, v-notch application

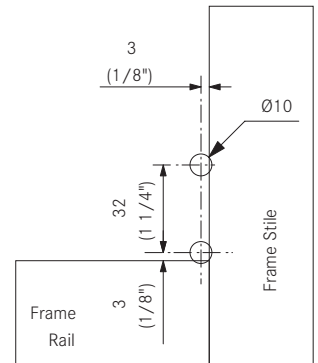

# Technical Information

## Elite Plus

### Elite Plus Application

- For drawer material from 12.7mm (1/2") up to 19mm (3/4")
- For frameless or face frame application
- Use rear bracket for face frame application

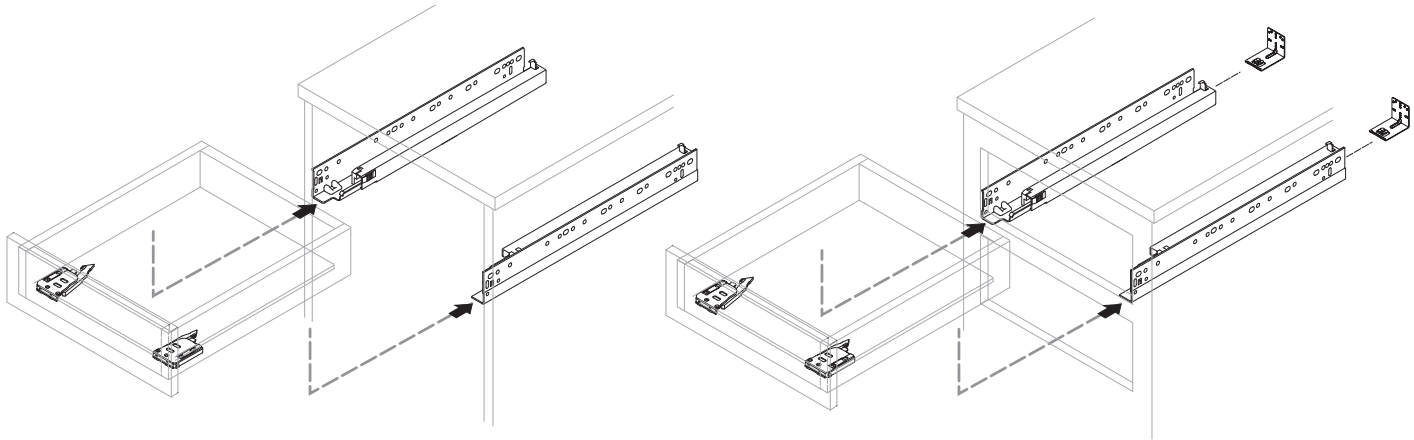

### Inserting the Drawer

Place drawer on extended Elite Plus slide and push in until it engages audibly

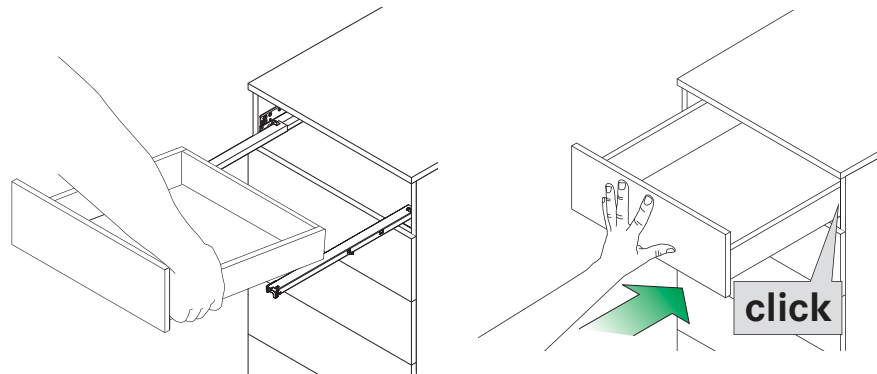

### Disengaging the Drawer

Pull the drawer out, squeeze the locking device levers and lift drawer from the slide.

#### 1D Front Locking Device

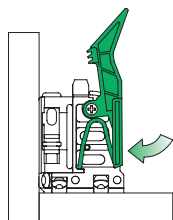
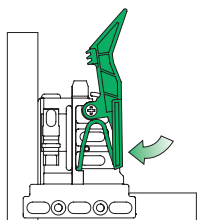

Flanged Front Locking Device

Front Locking Device

#### 2D Front Locking Devices

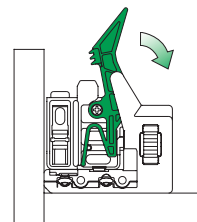
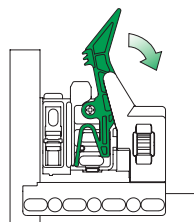

Flanged Front Locking Device

Front Locking Device

### 7523 Front Locking Device, 1D, Adjustment

Height Adjustment (max +2.5mm)

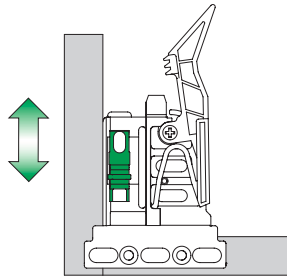
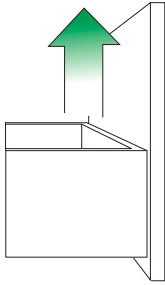

Flanged Front Locking Device

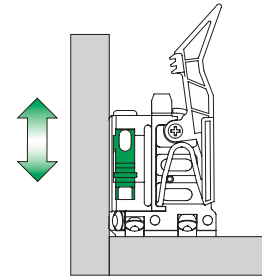

Front Locking Device

### 75X3 Front Locking Device, 2D, Adjustment

Height Adjustment (max +2.5mm)

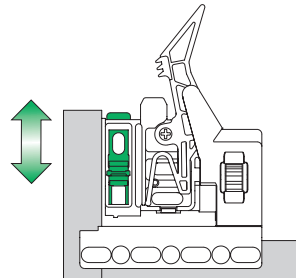
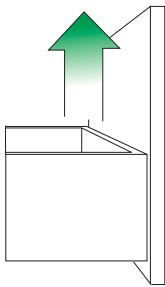

Flanged Front Locking Device

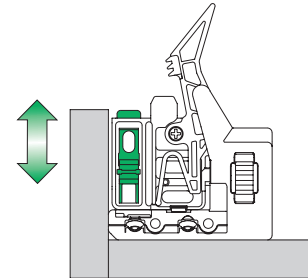

Front Locking Device

Side Adjustment (max ±1.5mm)

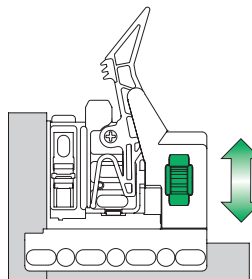
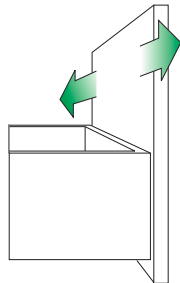

Flanged Front Locking Device

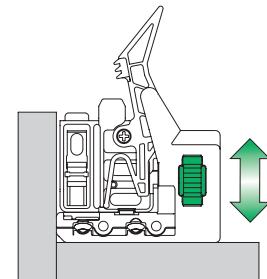

Front Locking Device

### Weight Capacities per Pair of Slides

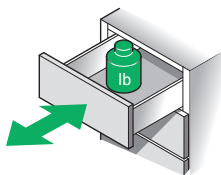

Elite Plus: 100 lb dynamic load rating; 100 lb static load rating

Elite Plus meets and exceeds the minimum requirements of ANSI/BHMA A156.9 Standard, Grade 1

# Elite Plus 16

## Full Extension Slide for 16mm (5/8") drawer material



- Zinc plated, roll formed steel components
- Precision, smooth-running synthetic roller carriages
- Liquid damper softly glides drawers to a stop
- Self-latching front locking devices have comfortable release levers for drawer removal and installation
- Full extension for complete drawer access
- Height adjustment +2.5mm (3/32") with suitable front locking device
- Side adjustment ±1.5mm (1/16") with suitable front locking device
- Positive tracked right side, ± 1.5mm (1/16") side tolerance on left side
- Self-closing mechanism engages 30mm (1 1/4") before closed position
- Weight capacity: 100 lb dynamic, 100 lb static
- Meets and exceeds ANSI/BHMA A156.9 Standard, Grade 1

### Elite Plus 16



Drawer Length	Nominal length	Min Installation Depth	Max Installation Depth	Item No.	PU
240 (9 7/16")	250 (9 27/32")	259 (10 3/16")	296 (11 5/8")	13132-03	5
305 (12")	317 (12 15/32")	329 (12 15/16")	363 (14 5/16")	13133-03	5
381 (15")	394 (15 1/2")	407 (16")	440 (17 5/16")	13363-03	5
457 (18")	470 (18 1/2")	479 (18 7/8")	516 (20 5/16")	13364-03	5
533 (21")	550 (21 21/32")	562 (22 1/8")	596 (23 7/16")	13365-03	5
381 (15")	394 (15 1/2")	407 (16")	440 (17 5/16")	13363-12	200
457 (18")	470 (18 1/2")	479 (18 7/8")	516 (20 5/16")	13364-12	200
533 (21")	550 (21 21/32")	562 (22 1/8")	596 (23 7/16")	13365-12	200

\*For frameless applications, deduct 1.5mm (1/16") for minimum installation depth

### Front Locking Devices and Rear Mounting Bracket



Description	Non-flanged Item No. (a)	Flanged Item No. (b)	PU
(Must order separately)			
1 7523 Front locking device, universal, 1D, kit*	02500-03	-	5
7523 Front locking device, universal, 1D, left	02498-12	02495-12	200
7523 Front locking device, universal, 1D, right	02499-12	02496-12	200
2 75X3 Front locking device, universal, 2D, left	80051-12	80053-12	200
75X3 Front locking device, universal, 2D, right	80052-12	80054-12	200
3 Universal rear mount bracket		7950.VE300	200

\*Kit: Left/Right locking device, (4) #6 x 1/2" flat head Phillips screws, \*\*Plug-in brackets available on page 14

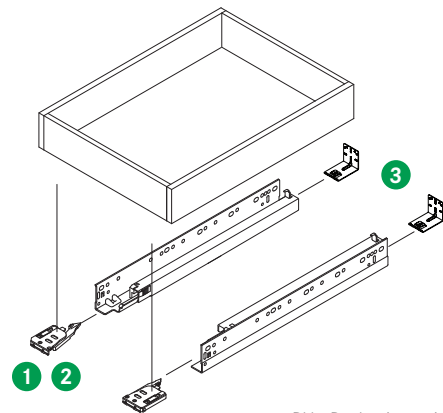

PU - Packaging unit

**Drawer Measurements/Rear Bracket Position      Drawer Installation Dimensions**

**Drawer Measurements**

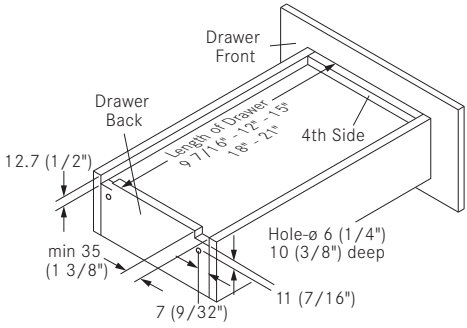

**Rear Bracket for Face Frame**

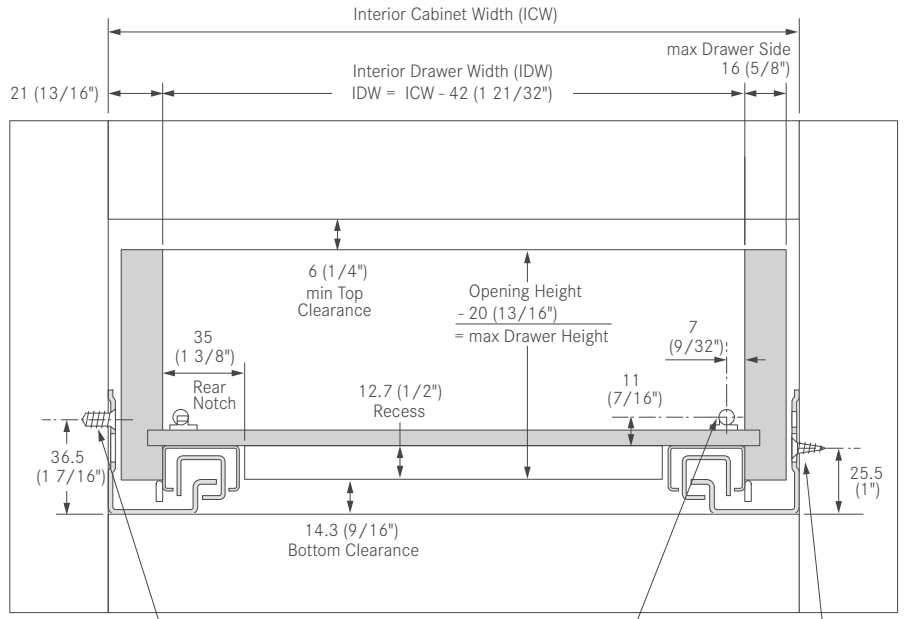
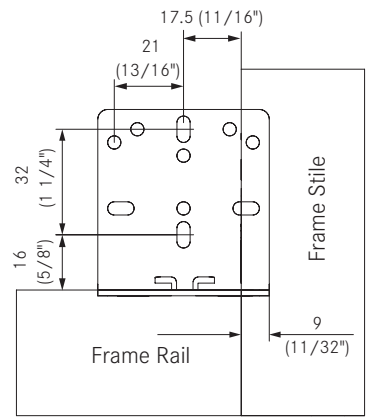

Euro screw Ø5 x 13mm or #7 x 5/8" flat head wood screw location on panel cabinets  
 Ø6 x 10 (1/4" x 3/8") Hole in back of drawer for catch hook  
 #7 Wood screw location at face frame

For face frame applications only. Use minimum of 3 screws per bracket, #6 x 1/2" truss head screws.

**Cabinet Boring Specifications**

**Face Frame**

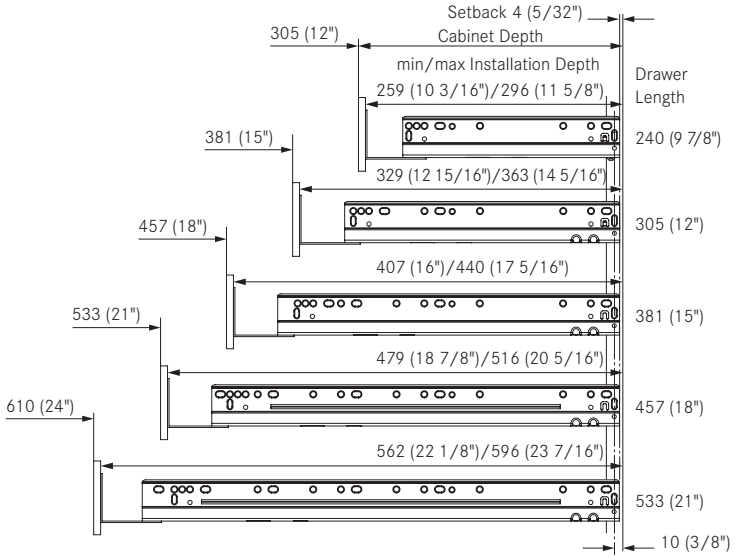

**Frameless**

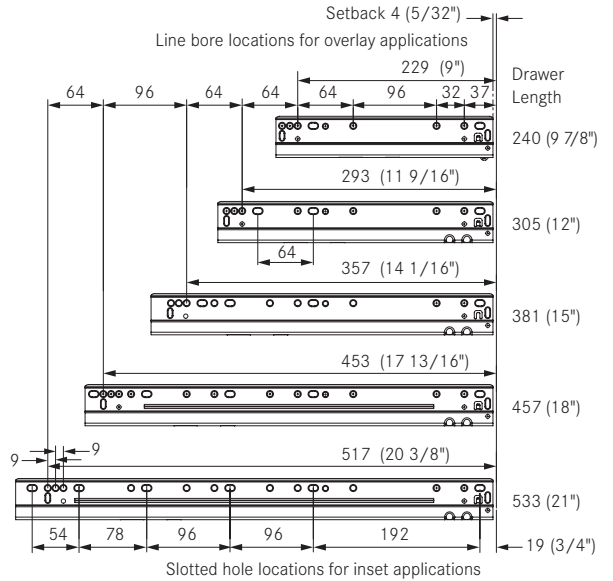

# Elite Plus 19

## Full Extension Slide for 19mm (3/4") drawer material



- Zinc plated, roll formed steel components
- Precision, smooth-running synthetic roller carriages
- Liquid damper softly glides drawers to a stop
- Self-latching front locking devices have comfortable release levers for drawer removal and installation
- Full extension for complete drawer access
- Height adjustment +2.5mm (3/32") with suitable front locking device
- Side adjustment ±1.5mm (1/16") with suitable front locking device
- Positive tracked right side, ± 1.5mm (1/16") side tolerance on left side
- Self-closing mechanism engages 30mm (1 1/4") before closed position
- Weight capacity: 100 lb dynamic, 100 lb static
- Meets and exceeds ANSI/BHMA A156.9 Standard, Grade 1

### Elite Plus 19



Drawer Length	Nominal length	Min Installation Depth	Max Installation Depth	Item No.	PU
240 (9 7/16")	250 (9 27/32")	259 (10 3/16")	296 (11 5/8")	13183-03	5
305 (12")	317 (12 15/32")	329 (12 15/16")	363 (14 5/16")	13184-03	5
381 (15")	394 (15 1/2")	407 (16")	440 (17 5/16")	13185-03	5
457 (18")	470 (18 1/2")	479 (18 7/8")	516 (20 5/16")	13186-03	5
533 (21")	550 (21 21/32")	562 (22 1/8")	596 (23 7/16")	13139-03	5
457 (18")	470 (18 1/2")	479 (18 7/8")	516 (20 5/16")	13186-12	200
533 (21")	550 (21 21/32")	562 (22 1/8")	596 (23 7/16")	13139-12	200

\*For frameless applications, deduct 1.5mm (1/16") for minimum installation depth

### Front Locking Devices and Rear Mounting Bracket



Description	Non-flanged Item No. (a)	Flanged Item No. (b)	PU
(Must order separately)			
1 7523 Front locking device, universal, 1D, kit*	02500-03	-	5
7523 Front locking device, universal, 1D, left	02498-12	02495-12	200
7523 Front locking device, universal, 1D, right	02499-12	02496-12	200
2 75X3 Front locking device, universal, 2D, left	80051-12	80053-12	200
75X3 Front locking device, universal, 2D, right	80052-12	80054-12	200
3 Universal rear mount bracket		7950.VE300	200

\*Kit: Left/Right locking device, (4) #6 x 1/2" flat head Phillips screws, \*\*Plug-in brackets available on page 14

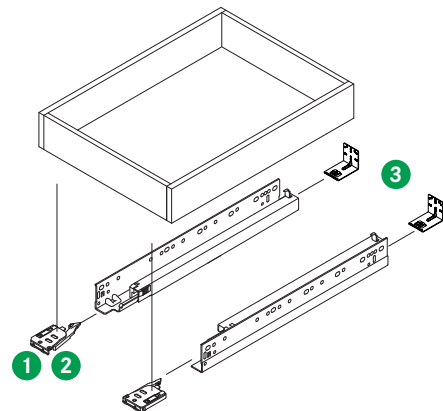

PU - Packaging unit

**Drawer Measurements/Rear Bracket Position      Drawer Installation Dimensions**

**Drawer Measurements**

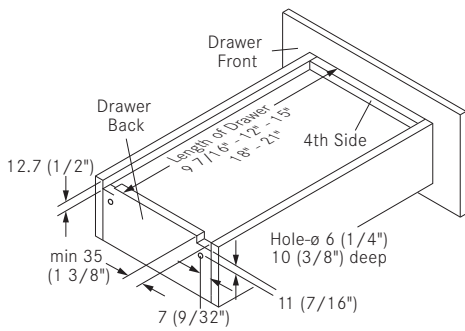

**Rear Bracket for Face Frame**

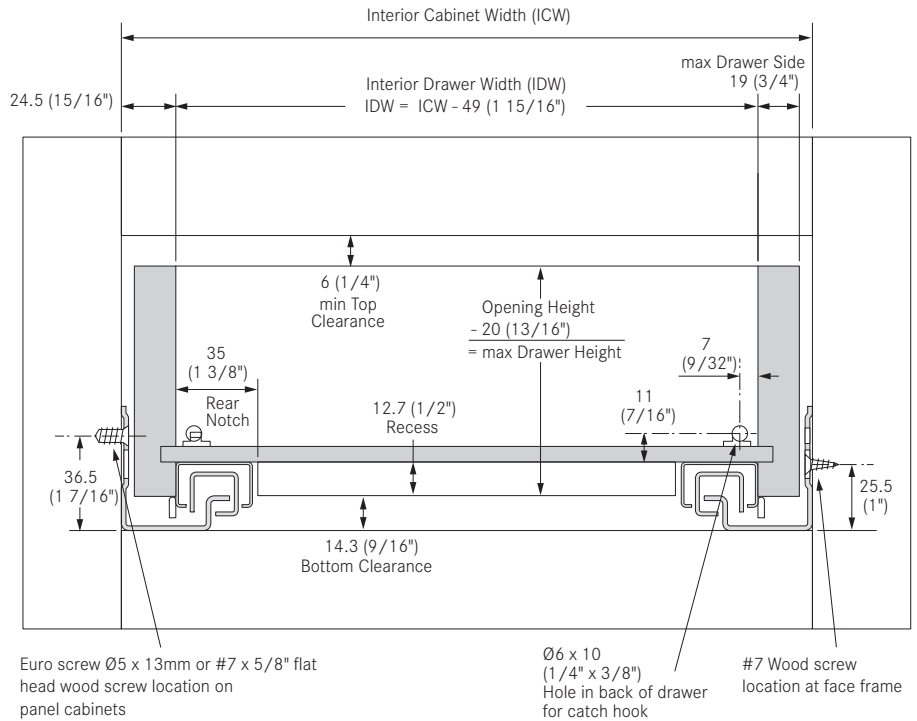
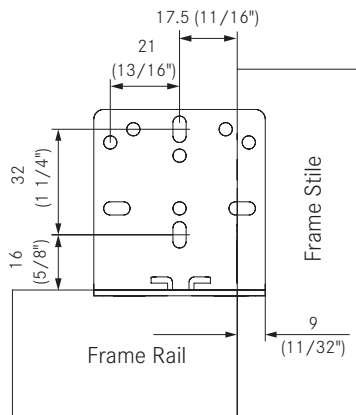

For face frame applications only. Use minimum of 3 screws per bracket, #6 x 1/2" truss head screws.

**Cabinet Boring Specifications**

**Face Frame**

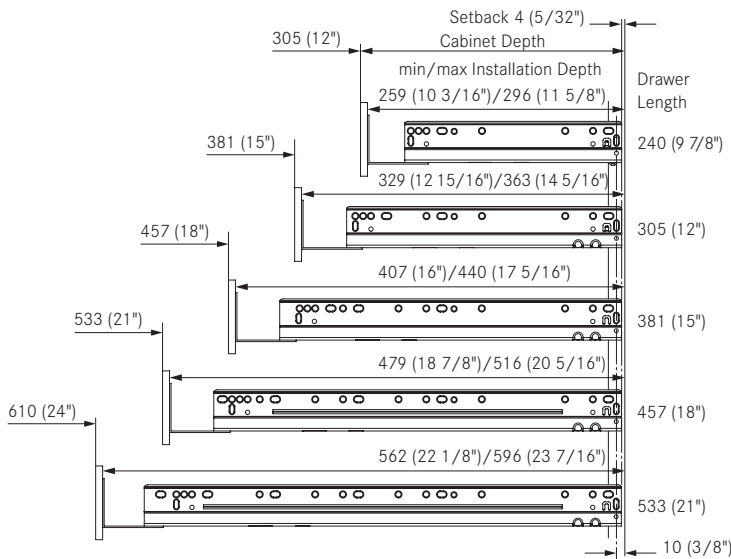

**Frameless**

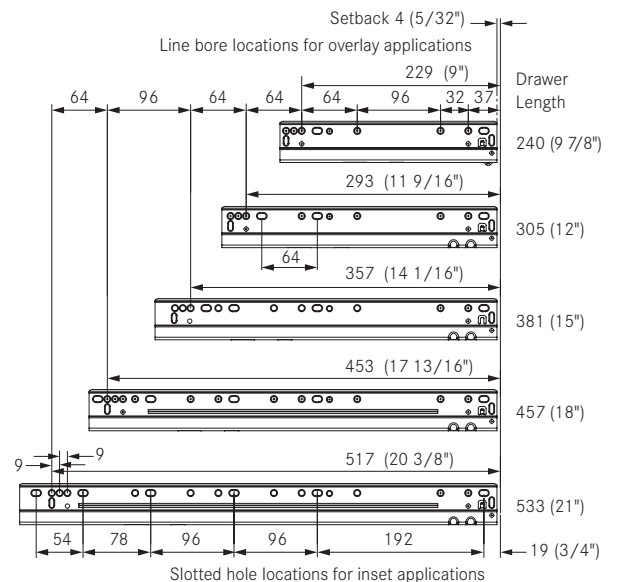

# Accessories and Assembly Aids

## Elite Plus

### V-notch Rear Mounting Brackets, 19mm



No Socket



With Socket

- 19mm rear mounting brackets
- Side-to-side adjustment  $\pm 6\text{mm}$  (1/4")
- Brackets attach to cabinet member with Euro screws

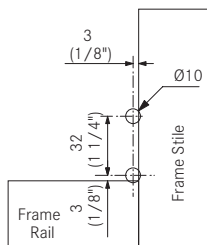

Description	Item No.	PU
1 V-notch, metal, no socket, left	02212-12	200
V-notch, metal, no socket, right	02213-12	200
2 V-notch, metal, with socket, left	02216-12	200
V-notch, metal, with socket, right	02217-12	200

### Drilling Template



- Use to precisely bore holes in the drawer back
- Use with a standard 6mm (1/4") drill bit and stop collar

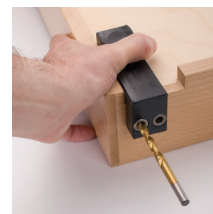

Left Side Drilling

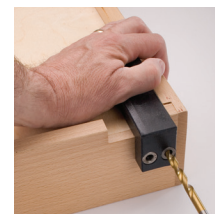

Right Side Drilling

Description	Item No.	PU
Elite Plus drilling template	02511-01	1

### Assembly Aids



The non-flanged FLD drilling jig is used for mounting non-flange front locking devices to the drawer box for Dynapro, Dynapro2.0, Elite Plus, and Maxcess.

The GRASS centering drill bit is used for pre-drilling countersink wood screws,  $\text{Ø} 2.5\text{mm}$ .



1

2

Description	Item No.	PU
1 Non-flanged FLD drilling jig	00004	1
2 Centering drill bit	35692-01	1

PU - Packaging unit

## Elite Plus

### Screws

#### Euro Screw, Nickel-plated



Description	Item No.	PU
Euro Screw 11mm (7/16") Pozi	499.360.61.1015	500
Euro Screw 13mm (1/2") Pozi	499.360.61.3015	500

#### Wood Screw, Nickel-plated

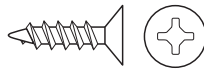

Description	Item No.	PU
#6 x 5/8" FHP, NI	81001-43	500
#6 x 3/4" FHP, NI	81003-43	500

### Bumper Pads

#### Bumper Pads, Self-adhesive

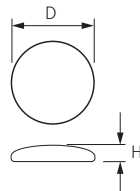

Description	Height	Diameter	Item No.	PU
Bumper pad, clear	2.5mm	10mm	63407-99	288
Bumper pad, clear	2.5mm	10mm	63407-47	7200

#### AirSoft Bumper Pads, Self-adhesive

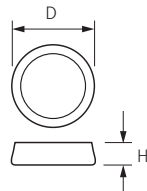

Description	Height	Diameter	Item No.	PU
AirSoft bumper pad, clear	5mm	12.7mm	63481-43	500
AirSoft bumper pad, clear	5mm	12.7mm	63483-30	5000

#### Bumper Pads, Self-adhesive

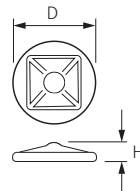

Description	Height	Diameter	Item No.	PU
Bumper pad, clear	4mm	12mm	630.000.02.1250	5000

#### Bumper Pads, Self-adhesive

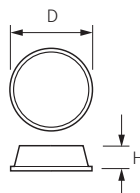

Description	Height	Diameter	Item No.	PU
Bumper pad, clear	3mm	12.7mm	31002-43	500
Bumper pad, clear	1.5mm	12.7mm	31004-43	500



GRASS America Inc.  
1202 NC Highway 66 South  
Kernersville, NC 27284

Phone: 1-800-334-3512  
Fax: 1-800-525-8406

[www.grassusa.com](http://www.grassusa.com)  
[info@grassusa.com](mailto:info@grassusa.com)

