



Mounting

The TIP-ON unit can be either bored into the cabinet end panel or attached to the cabinet interior using adapter plates.



Catch plate

The catch plate is the counterpart to TIP-ON. It is available in self-adhesive or screw-on versions.



Hinges

Free swing hinges are used with TIP-ON for doors with magnet/self close hinges are used with TIP-ON for doors with bumper.

TIP-ON for doors Opening Comfort for Doors Without Handles

Doors can be opened easily with TIP-ON – a light touch is all that's needed

- Designed for frameless or face frame (blocked out) cabinet applications
- Works with CLIP top BLUMOTION, CLIP top, CLIP, COMPACT BLUMOTION and COMPACT
- Can be bored into the side panel or used with an adapter plate
- Easy depth adjustment for proper door gap setting
- Works for both overlay and inset applications
- Quick and easy installation
- Increased design options
- Requires minimal force to open and close

Tool-Free Door Gap Adjustment

The adjustment feature (+4 mm, -1 mm) has been incorporated into the TIP-ON unit so even when TIP-ON is inserted into the cabinet, it has an integrated gap adjustment. To adjust gap, turn the ejector pin. The click-stop positions allow you to easily find the right setting.



TIP-ON boring specifications

Standard TIP-ON set

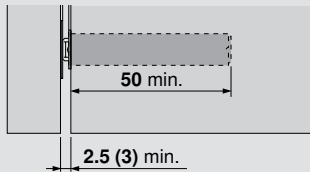

Large TIP-ON set

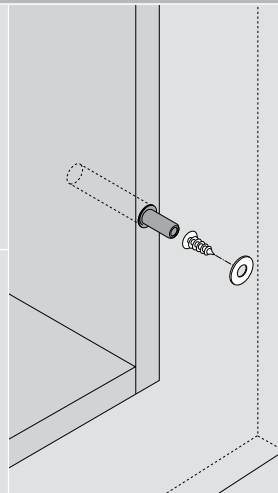
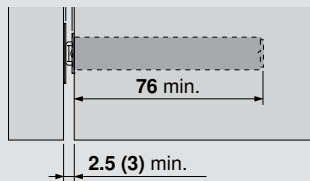

Catch plate (screw-on)

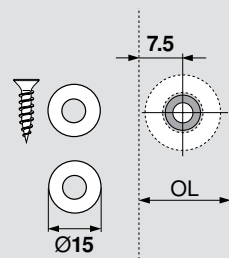

Pre-boring Ø2.5 mm counter-sunk pilot holes required

OL = Door overlay

Catch plate (self-adhesive)

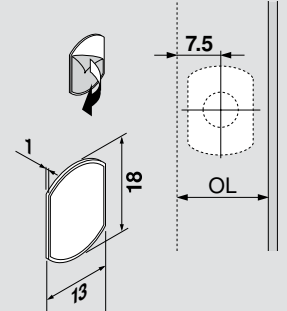

Cleaning of the door surface is recommended

NOTE: Minimum gap of 3 mm with a screw-on catch plate and 2.5 mm with a self-adhesive catch plate

TIP-ON in-line and wing adapter plate specifications

In-line adapter plate

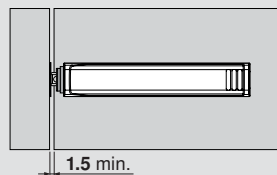

Wing adapter plate

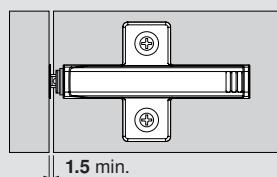

Catch plate (screw-on)

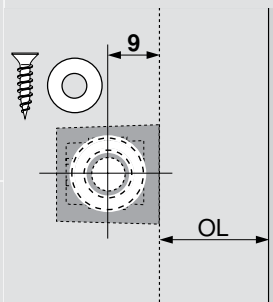

Pre-boring Ø2.5 mm counter-sunk pilot holes required
OL = Door overlay

Catch plate (self-adhesive)

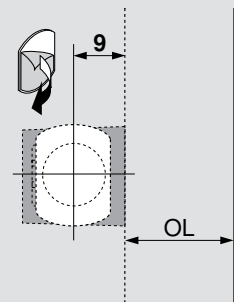

Cleaning of the door surface is recommended

Installation position



Optimal opening support is achieved if the TIP-ON unit is attached exactly where the handle would be.

The fixing position can deviate ±12" in height and up to a quarter of the cabinet width in terms of width.

NOTE: Factory setting of door gap is 2 mm

NOTE: Minimum gap of 3 mm with a screw-on catch plate and 2.5 mm with a self-adhesive catch plate

TIP-ON set for standard door



- White
- Gray
- Black

Overlay

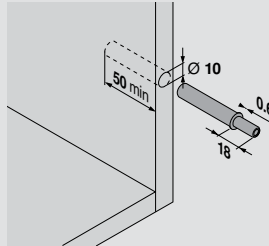

Inset

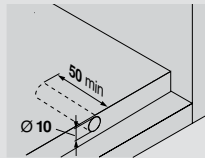

- For use with Blum CLIP free swing hinges
- Nylon unit with magnet tip
- Adjustment range +4 mm to -1 mm
- For door heights less than 48"
- Works for overlay and inset applications
- Can be bored into the panel or used with an adapter plate

Set includes:

- TIP-ON unit
- Self-adhesive catch plate
- Screw-on catch plate
- Wood screw

Part no.

NOTE: Due to various door weights and sizes, trial application recommended

Standard door set

956.1004

TIP-ON set for large door



- White
- Gray
- Black

Overlay

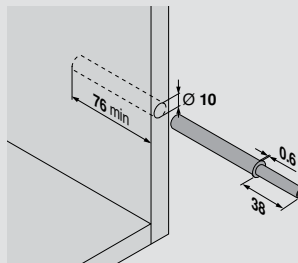

Inset

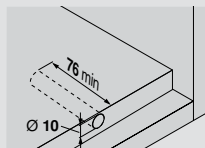

- For use with Blum CLIP free swing hinges
- Nylon unit with magnet tip
- Adjustment range +4 mm to -1 mm
- For door heights greater than 48"
- Works for overlay and inset applications
- Can be bored into the panel or used with an adapter plate

Set includes:

- TIP-ON unit
- Self-adhesive catch plate
- Screw-on catch plate
- Wood screw

Part no.

NOTE: Due to various door weights and sizes, trial application recommended

Large door set

956A1004

TIP-ON unit for self/soft close hinges



- White
- Gray
- Black

Overlay

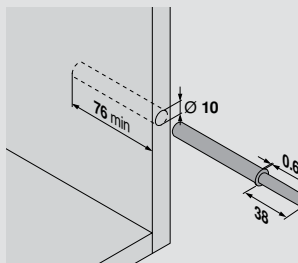

Inset

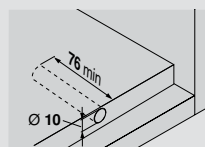

- For use with Blum self/soft close hinges
- Nylon unit with bumper tip
- Adjustment range +4 mm to -1 mm
- For door widths greater than 10"
- Works for overlay and inset applications
- Can be bored into the panel or used with an adapter plate

Part no.

NOTE: Due to various door weights and sizes, trial application recommended

Self/soft close hinges

956A1006

TIP-ON in-line adapter plate for standard door



- White
- Gray
- Black
- Nickel

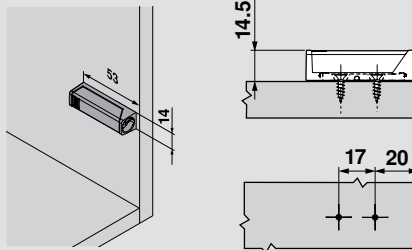

- In-line adapter plate for standard door
- Two-piece, screw-on base plate
- 20 mm setback, 17 mm apart
- Door gap factory setting 2 mm
- Nylon

Application	Setback
Overlay	20
Inset	22 + door thickness

	Part no.
Screw-on in-line adapter	956.1201
Installation screw	606N or 606P

NOTE: For face frame applications, blocking out may be required

TIP-ON in-line adapter plate for large door



- White
- Gray
- Black
- Nickel

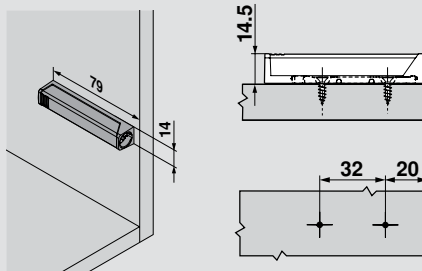

- In-line adapter plate for large door
- Two-piece, screw-on base plate
- 20 mm setback, 32 mm apart
- Door gap factory setting 2 mm
- Nylon

Application	Setback
Overlay	20
Inset	22 + door thickness

	Part no.
Screw-on in-line adapter	956A1201
Installation screw	606N or 606P

NOTE: For face frame applications, blocking out may be required

TIP-ON wing adapter plate for large door



- Gray

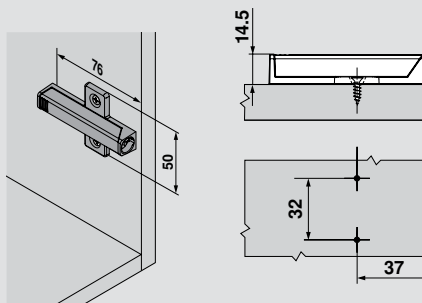

- Wing adapter plate for large door
- One-piece, screw-on wing plate
- 37 mm setback, 32 mm apart
- Door gap factory setting 2 mm
- Gray nylon

Application	Setback
Overlay	37
Inset	39 + door thickness

	Part no.
Screw-on wing adapter	956A1501
Installation screw	606N or 606P

NOTE: For face frame applications, blocking out may be required

TIP-ON for doors